



OAKWRIGHTS®

Country Buildings

Adding beautiful space to your home

I'm passionate about creating spaces that enhance our customers' lives.

Our country buildings encompass a beautiful range of oak frame structures for your garden. We're talking about garages, barns, stables and leisure pavilions.

Through our conversations, we'll learn what you want to achieve, and we'll design and present you with the opportunities available to you.

People use Oakwrights Country Buildings in myriad ways. If you have a beautiful car, you may want somewhere beautiful to store it. With our garages, you can even create some additional space above your garage for other purposes.

Perhaps a workshop is more your thing. Our customers create workshops for all kinds of reasons. The hobbyist may want the space for an expansive train set. A keep fit fan may want to create a gym or a yoga studio so they can stay in great shape. Others want to plunge into their own indoor pool every morning...

These are just a few examples of what we can create together.

Take a look through our brochure for a few more ideas of how to enhance your whole lifestyle.

Charlie Mills
Managing director, Oakwrights



Contents

About Oakwrights	4
Oakwrights Country Buildings	6
Garages	10
Bespoke Outbuildings: stables, barns and pavilions	22
Contact us	31

About Oakwrights

We are a multi-award-winning company, specialising in the design and construction of all styles of oak frame buildings.

Born in the delicious Herefordshire countryside, we are proud to have created buildings for customers nationwide.

Each frame we create is a celebration of life. Built from solid timber – our planet's most plentiful, sustainable and aesthetically pleasing construction resource – our buildings always work in harmony with their surroundings.

Our philosophy is simple. We provide the highest level of service to help you acquire the highest quality building. We achieve this by investing in the very best tools and the very best people. We all work together as a team to support, develop and enthuse each other.



Come and see us!

We encourage customers to visit us. We enjoy showing people around our offices and state-of-the-art workshops and answering their questions. We want you to see how we work and how your project will come to life.

Each of our projects is a unique creation, developed in partnership with you, our customers. Please feel free to contact us if you have any questions at all about our company or your specific project.

Thank you for considering Oakwrights.



About Oakwrights Country Buildings

You don't need to travel far to get away from it all. Our country buildings offer you a real sense of freedom at the bottom of your garden.

Oakwrights outbuildings are the perfect place to tinker, to potter or just relax. We have created thousands during the years we've existed as a company. This means we have worked with local authorities right across the UK. Unsurprisingly, we have an excellent track record of gaining planning approval from those authorities. We do this by working with you and them to achieve the best outcome.

So, when you commission us to create your country building, it's time for you to relax. We have the skills, the equipment, the knowledge and the people to provide you with the most precise oak frame building possible.



Stress relief

They can also make commuting a thing of the past. Just think how you would feel every morning, strolling across the dew of your lawn to your own private office. An office imbued with the subtle scent of real wood and natural light.

Step into your very own oak haven, with Oakwrights.



Defining our services

We're here to guide you through the various options. We leave it to you to decide what works best for you.

We can supply and assemble the building for you, or we can supply the frame only, ready to be erected by your carpenter.

If you wish, we can also supply and fit the roof for you. The choice is entirely yours.

Planning permission

We will be happy to manage any planning permission or listed building consent you need. We'll quote the costs of this service as part of our overall design and build package.

We can also provide individual quotes (independent of any package).



Garages



Our standard single storey oak frame garages are a beautiful addition to your home. Available with a variety of roof and pitch styles, we can create one that perfectly suits you.



Cosset your car... or cars

We have ready-made plans for single storey garages of two or more bays. You just need to let us know if you want yours open-fronted or closed. You can always add a doorway or two and windows to let the light in. You can also incorporate a log store or allow space for a muddy mountain bike or two. In other words, we have the plans in place to provide you with your perfect oak frame garage.

Single storey oak garages have become increasingly popular over recent years as they fall within the elevation height restrictions set out under permitted development.*

All are manufactured from high-quality green oak and produced by the finest craftsmen in the business.

** Some restrictions apply. Talk to our team to find out more.*



Standard oak frame single storey garage range



Kenchester

This traditional two-bay oak frame garage will beautifully compliment your home, and is available in any number of bays. The Kenchester is designed to be under 4m to the ridge, through the use of the cat slide roof. Therefore, this garage can be built without planning permission (subject to your local authority provisos).



Highgrove

The Highgrove shares the same footprint as the Kenchester, without the cat slide roof. Its generous height, which runs throughout its depth, makes it an extremely usable building, especially if you own a larger vehicle or if you want to use it as an office, workshop or gym. It can also be supplied with a drive-through bay, which allows access behind the building, whether you choose the 27° or 35° roof pitch. A garage with a 27° roof pitch can be built without planning permission (subject to your local authority provisos).



Cotswold

The Cotswold uses the Little Gloucester's footprint (see p16, which results in the most capacious single storey option in our range. So, while all our timber frame garages can comfortably swallow a Land Rover Discovery, the Cotswold's additional depth and width makes it the ideal choice for those looking for even more than a beautiful home for their chunky 4x4. A garage with a 25° roof pitch can be built without planning permission (subject to your local authority provisos).



Canterbury

Not all cars are built equally. Hence, the Canterbury. Its generous bay widths and depth mean almost any 4x4 can be accommodated. We can customise this garage and add as many bays as you want. Supplied with its planning drawings, we can have the Canterbury sitting on your driveway in no time at all.

*All bay widths from 2.8m up to 3m.
Some restrictions apply. Talk to our team to find out more.

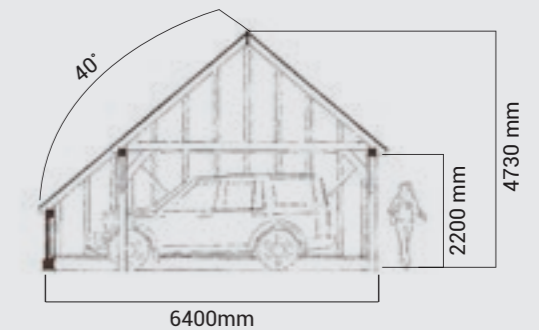
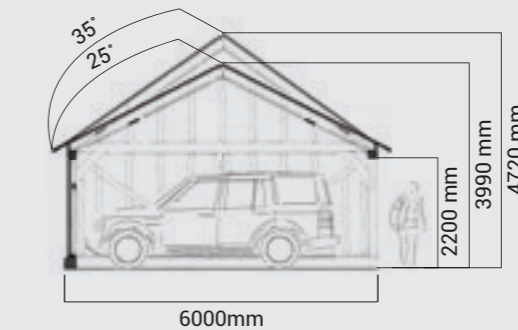
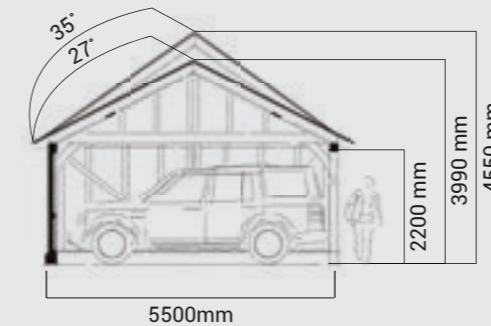
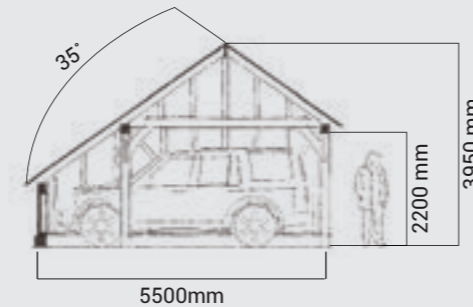

Enjoy another storey...

Saunter across the lawn, skip up the stairs and enter your very own studio. This room-over your garage can make you feel like you're miles from anywhere.

Which is perfect when you want to shut yourself away to indulge in a hobby or focus on some work.

When you're done, the commute home is also a doddle. Simply slip your shoes back on and retrace your footsteps across your lawn.



Standard oak frame room-over garage range



Little Gloucester

The Little Gloucester room-over garage offers a great solution for those wanting a little extra space. The stairs leading up to the room are placed on the outside, so they don't impinge on your garage space. It will be supplied with the number of bays you want.



Gloucester

The Gloucester is the ideal choice for those who want a studio, games room or a gymnasium over their garaging space. In tandem with its smaller sibling, its stairs are placed on the outside and it is available in any number of bays, to suit your needs.



Portchester

The Portchester has a more discreet presence but a surprising amount of space, thanks to its asymmetric timber frame. In tandem with our other room-over garages, its stairs are placed on the outside to maximise interior space.



Winchester

This cavernous room-over garage is the highest in our range. Its height comes courtesy of a roofline that starts a metre above the upstairs floor height. This makes the Winchester extremely popular with customers looking to maximise habitable space.

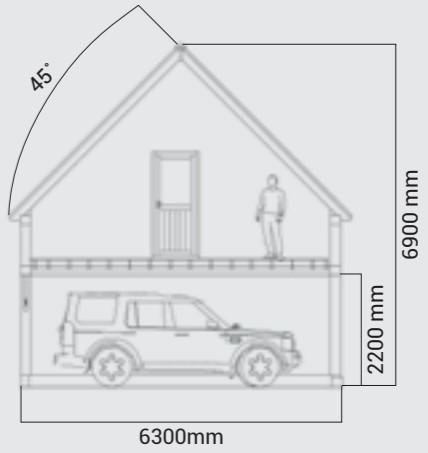
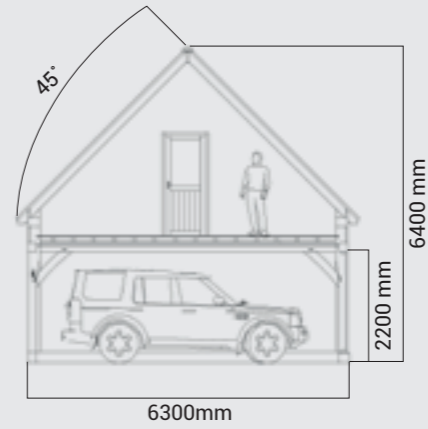
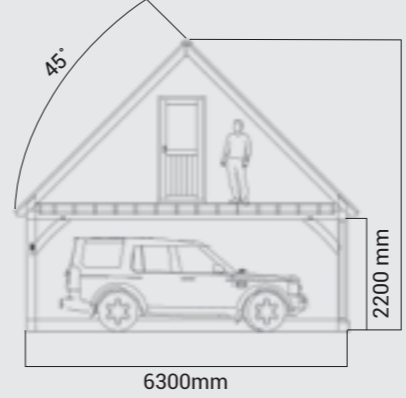
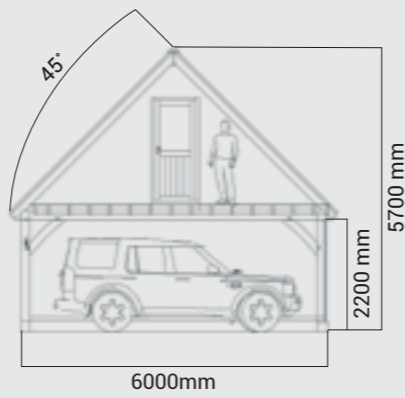



“Some of our customers use their room-over for a home office, a photography-, art- or yoga studio, a gym or as accommodation for guests. They love the fact that this highly useful space is possible without increasing the footprint of their garage.”

Charlie Mills
Managing director, Oakwrights





Bespoke Outbuildings

Stables | Barns | Pavilions





Stables fit for thoroughbreds

Whether you are looking for ideal accommodation for your horse or pony, or you are looking to expand your professional yard, we will be happy to work with you to fulfil your equestrian ambitions.

As well as your needs, we'll also take your surroundings into consideration to ensure our designs coordinate beautifully.

We can create a multipurpose building that incorporates as many bays as you want as well as rooms above.

Add wash facilities and tack rooms, hay storage and trailer- or lorry parks and groom accommodation to create the stables of your dreams.

Beautiful barns

Whether you'd simply like some additional space, or you hanker for a handy hideaway, our garden barns offer the perfect solution.

Our barns feature high-vaulted ceilings and can incorporate swathes of glass to allow the light to flood the interior.

You can transform your barn into a multifunctional space by adding a mezzanine floor. Our customers use theirs for playrooms, entertainment spaces, studios as well as guest accommodation.

However you'd like to extend your living space into your garden, see our contact details at the end of this brochure to learn how to get in touch with our helpful team members.



Fancy popping out for a drink?

We're lucky to have some fantastic hostelries across the country in which to socialise with friends.

But how nice would it be to saunter down your garden path to your very own outdoor bar? Our green oak frame structures are available in classic and modern designs.



“Our pavilions are becoming ever more popular with our customers. They love using them as a discrete little outdoor space that’s as versatile as their imaginations. By adding a string of lightbulbs from tree branches you can transform your garden into an enchanting space.”

Charlie Mills
Managing director, Oakwrights



We look forward
to hearing from you:

01432 353353

enquiries@oakwrights.co.uk

oakwrights.co.uk



OAKWRIGHTS®

The Lakes, Swainshill, Hereford, HR4 7PU

01432 353353 | enquiries@oakwrights.co.uk | oakwrights.co.uk